

VISUAL PERFORMANCE® SERIES

EXTREME: VP65 XT, VP65R XT, VP65S XT, VP65R SST XT



Product Family Overview

From the company that invented the category, comes the **BEST SOUNDING**, best looking and most complete range of in-wall and in-ceiling speakers ever. Visual Performance® Series

comes in various shapes and sizes to compliment down lights and décor and a complete range that allows you to enjoy a consistent aesthetic for any application in any room.



VP65 XT



VP65R XT



VP65S XT



VP65R SST XT

Features and Benefits

Visual Performance Extreme speakers are engineered for high humidity areas and are built to survive extreme temperatures. From -30°F up to +175°F (34°C up to +79 °C) while maintaining superior sound quality. Extreme speakers are shock resistance and withstand the pelting of the high seas and salt air, making them an excellent choice for marine applications.

- Samarium cobalt magnets on frames and grilles - will not rust
- 316L stainless steel grilles - will not rust
- Neoprene gasket behind frame- moisture barrier
- Santoprene™ surround on woofer, continuously maintains woofer suspension through extreme environmental conditions
- Two piece toggle feet allows installation with double dry wall and thicker ceiling and wall materials

VP65 XT Specifications

Width:	8 3/8" (213mm)
Height:	12 1/4" (311mm)
Depth:	2 1/2" (64mm)
Cut Out Width:	6 15/16" (176mm)
Cut Out Height:	10 3/4" (273mm)

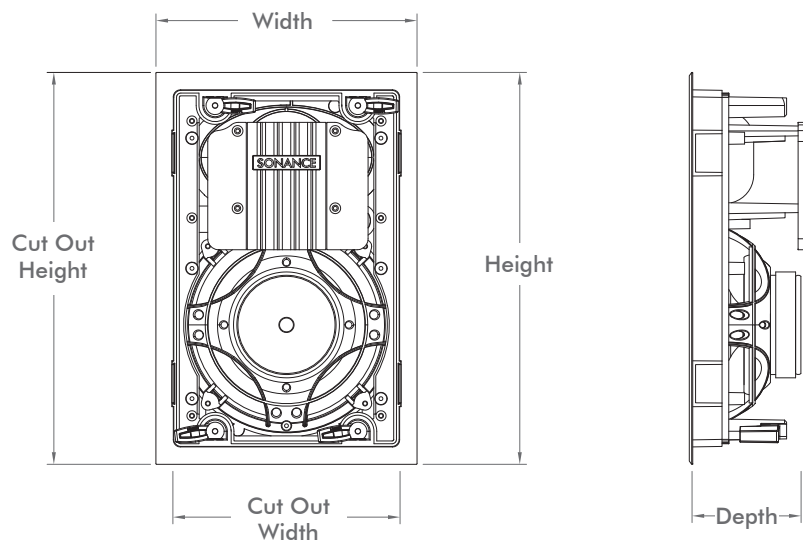

VP65R XT Specifications

Diameter: 9 3/4" (248mm)
Depth: 3 1/2" (89mm)
Cut Out Diameter: 8 1/4" (210mm)

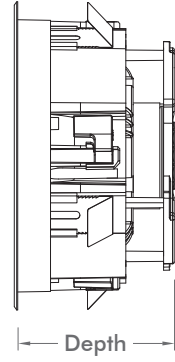
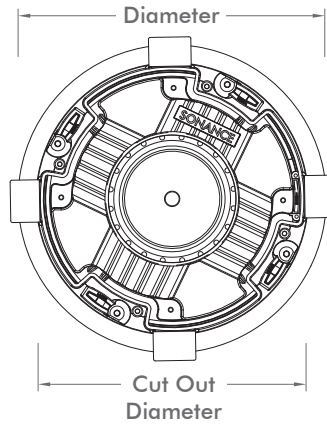

VP65S XT Specifications

Width: 9 7/8" (251mm)
Height: 9 7/8" (251mm)
Depth: 3 1/2" (89mm)
Cut Out Width: 8 1/4" (210mm)
Cut Out Height: 8 1/4" (210mm)

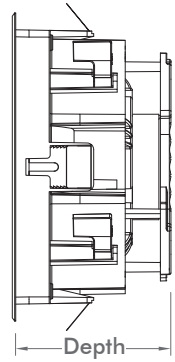
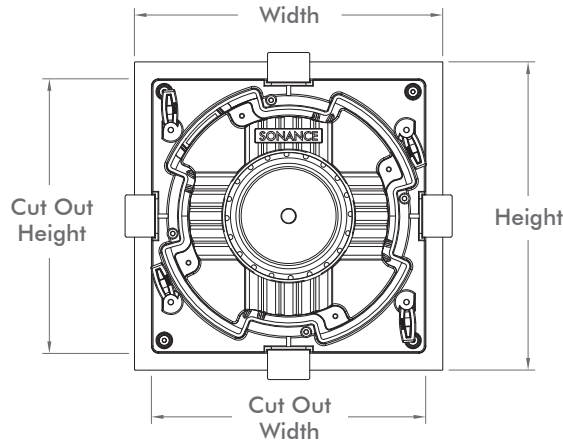

VP65R SST XT Specifications



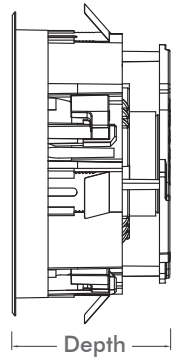
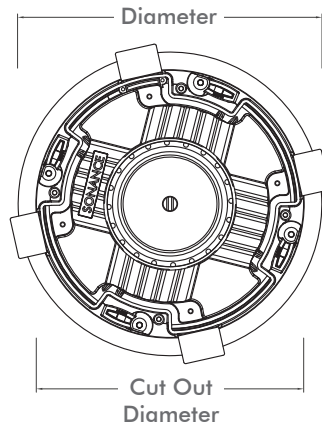

Diameter: 9 3/4" (248mm)
Depth: 5 3/16" (132mm)
Cut Out Diameter: 8 1/4" (210mm)



**VP65 XT****VP65R XT****VP65S XT****VP65R SST XT****SPECIFICATIONS**

SKU	92751	92752	92835	92753
UOM	Pair	Pair	Pair	Each
Tweeter	1" (25mm) polyurethane dome	1" (25mm) polyurethane dome	1" (25mm) polyurethane dome	Two 1" (25mm) polyurethane domes
Woofer	6 1/2" (165mm) injection-molded polypropylene/graphite cone, with integral Santoprene™ surround	6 1/2" (165mm) injection-molded polypropylene/graphite cone, with integral Santoprene™ surround	6 1/2" (165mm) injection-molded polypropylene/graphite cone, with integral Santoprene™ surround	6 1/2" (165mm) injection-molded polypropylene/graphite cone, with integral Santoprene™ surround
Frequency Response	55Hz - 20kHz ±3dB	55Hz - 20kHz ±3dB	55Hz - 20kHz ±3dB	55Hz - 20kHz ±3dB
Impedance	8 ohms nominal; 6 ohms minimum	8 ohms nominal; 6 ohms minimum	8 ohms nominal; 6 ohms minimum	8 ohms nominal; 6 ohms minimum
Power Handling	5 watts minimum; 130 watts maximum	5 watts minimum; 130 watts maximum	5 watts minimum; 130 watts maximum	5 watts minimum; 130 watts maximum
Sensitivity	89dB SPL (2.83V/1 meter)	89dB SPL (2.83V/1 meter)	89dB SPL (2.83V/1 meter)	89dB SPL (2.83V/1 meter)
Grille	Powder-coated stainless steel	Powder-coated stainless steel	Powder-coated stainless steel	Powder-coated stainless steel
Dimensions (WxHxD) or (Dia. x D)	8 3/8" x 12 1/4" x 2 1/2" (213mm x 311mm x 64mm)	9 3/4" x 3 1/2" (248mm x 89mm)	9 7/8" x 9 7/8" x 3 1/2" (251mm x 251mm x 89mm)	9 3/4" x 5 3/16" (248mm x 132mm)
Cut-Out Dimensions (WxH) or (Dia.)	6 15/16" x 10 3/4" (176mm x 273mm)	8 1/4" (210mm)	8 1/4" x 8 1/4" (210mm x 210mm)	8 1/4" (210mm)
Shipping Weight	12 lbs (5.4 kg) pair	12 lbs (5.4 kg) pair	12 lbs (5.4 kg) pair	4.5 lbs (2.1 kg) each

Associated Products for VP65 XT

Medium Rectangle Retrofit Enclosure (Pair Per Box)	92342		Medium Rectangle Acoustic Enclosure (Each)	91687	
Medium Rectangle Flex Bracket (5 Pair Per Box)	92336		Fire-Rated Listed Shallow Backcan (Each)	92807	
Medium Rectangle Masonry Bracket (Pair Per Box)	92066				

Associated Products for VP65R XT & VP65R SST XT

Medium Round Flex Bracket (5 Pair Per Box)	92337		Medium Round Acoustic Enclosure (Each)	91688	
Medium Round Retrofit Enclosure (5 Pair Per Box)	92343		Fire-Rated Listed Deep Backcan (Each)	92808	

Associated Products for VP65S XT

Medium Square Acoustic Enclosure (Each)	92474		Medium Square Flex Bracket (5 Pair Per Box)	92344	
Medium Round/Square Retrofit Enclosure (5 Pair Per Box)	92343		Fire-Rated Listed Deep Backcan (Each)	92808	

LIMITED LIFETIME WARRANTY

Sonance warrants to the first end-user purchaser that this Sonance-brand product ("Product"), when purchased from an authorized Sonance Dealer/Distributor, will be free from defective workmanship and materials for the life of the Product, except for the grille, which is warranted for five (5) years. Sonance will at its option and expense either repair the defect or replace the Product with a new or remanufactured Product or a reasonable equivalent. **Please visit our website and owner's e-Manual for complete warranty and exclusion information.**



©2013 Sonance. All rights reserved.

Sonance, Visual Performance and Roto-Lock, are registered trademarks of Dana Innovations.

Due to continuous product improvement, all features and specifications are subject to change without notice.

For the latest Sonance product specification information visit our website: www.sonance.com

SONANCE • 212 Avenida Fabricante • San Clemente, CA 92672-7531 USA

(800) 582-7777 or (949) 492-7777 • FAX: (949) 361-5151 • Technical Support: (800) 582-0772

www.sonance.com